

**Ultimate Circular Motion and Gravitation Assignment (16%)**

**Key Formulae:**

$$T = \frac{1}{f} \quad a_c = \frac{v^2}{r} = \frac{4\pi^2 r}{T^2} \quad F = G \frac{m_1 m_2}{r^2} \quad E_p = -G \frac{m_1 m_2}{r}$$

0108

1.

The diagram shows a student “twirling” a car key in a circular path on the end of a string.

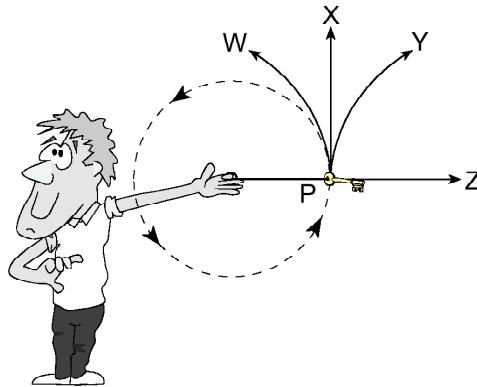

If the string snaps at P, which path will the keys follow?

- A. W
- B. X
- C. Y
- D. Z

2.

An athlete runs, at a constant speed, around a circle of radius 5.0 m in 12 s. What are the athlete’s speed and acceleration?

	SPEED	MAGNITUDE OF ACCELERATION
A.	0.42 m/s	0.22 m/s <sup>2</sup>
B.	0.42 m/s	1.4 m/s <sup>2</sup>
C.	2.6 m/s	0.22 m/s <sup>2</sup>
D.	2.6 m/s	1.4 m/s <sup>2</sup>

3.

A frictionless 3.0 kg cart rolls down an incline, and then “loops the loop.”

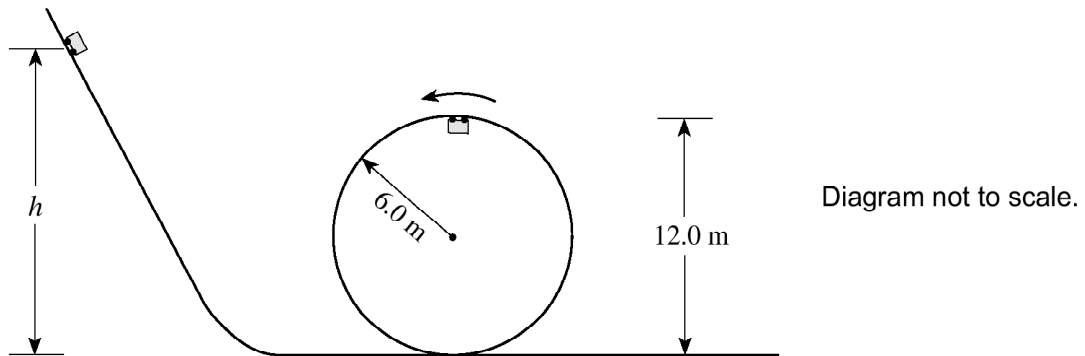

From what minimum height,  $h$ , should the cart be released so that it does not fall off the circular track?

- A. 12.0 m
- B. 15.0 m
- C. 18.0 m
- D. 24.0 m

4.

Which graph best shows how the gravitational field strength,  $g$ , varies with the distance,  $r$ , from the centre of a planet? ( $r_p$  is the radius of the planet.)

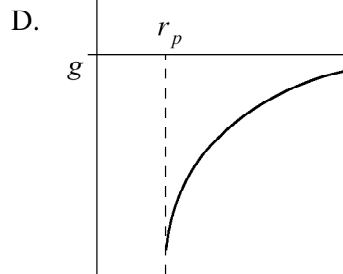
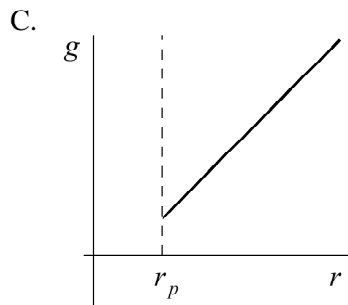
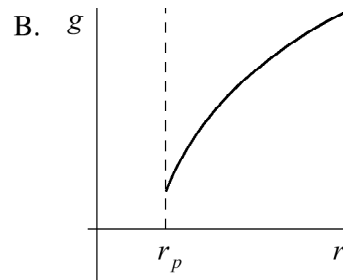
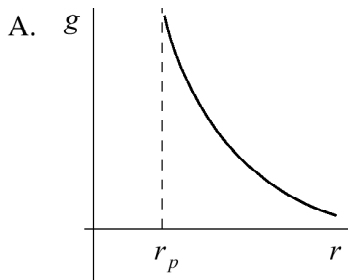

5.

A satellite is in a stable circular orbit around the earth. Another satellite in a stable circular orbit at a greater altitude must have

- A. a smaller speed and a shorter period.
- B. a smaller speed and a longer period.
- C. a greater speed and a shorter period.
- D. a greater speed and a longer period.

6.

Which of the following could represent the kinetic energy, the gravitational potential energy and the total energy for an orbiting satellite in a stable circular orbit?

	KINETIC ENERGY	GRAVITATIONAL POTENTIAL ENERGY	TOTAL ENERGY
A.	40 000 J	-80 000 J	-40 000 J
B.	40 000 J	40 000 J	80 000 J
C.	80 000 J	40 000 J	120 000 J
D.	80 000 J	-40 000 J	40 000 J

7.

A spacecraft of mass 470 kg rests on the surface of an asteroid of radius 1 400 m and mass  $2.0 \times 10^{12}$  kg. How much energy must be expended so that the spacecraft may rise to a height of 2 800 m above the surface of the asteroid? **(7 marks)**

0106

8.

A car travels at 25 m/s along a horizontal curve of radius 450 m. What minimum coefficient of friction is necessary between its tires and the road in order for the car not to skid?

- A. 0.14
- B. 0.54
- C. 0.72
- D. 1.4

9.

In a series of test runs, a car travels around the same circular track at different velocities. Which graph best shows the relationship between its centripetal acceleration,  $a_c$ , and its velocity,  $v$ ?

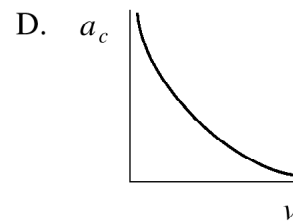
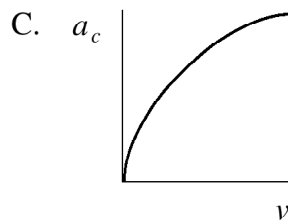
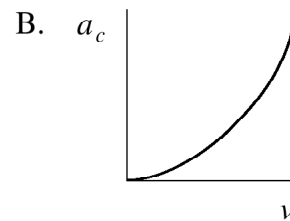
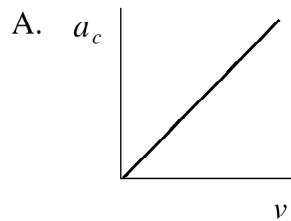

10.

Tarzan, of mass 85 kg, holds on to a horizontal vine of length 8.0 m and jumps off a cliff. What is the tension force in the vine as Tarzan passes the lowest point of his circular path?

- A. 830 N
- B. 1 700 N
- C. 2 500 N
- D. 6 700 N

11.

Which graph shows gravitational potential energy plotted as a function of distance  $r$  from the centre of the earth?

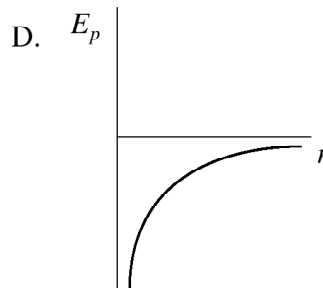
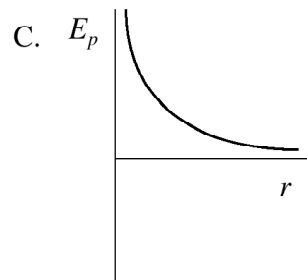
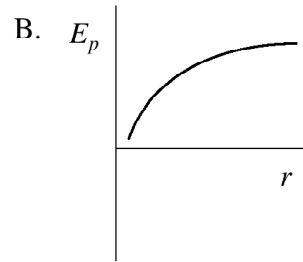
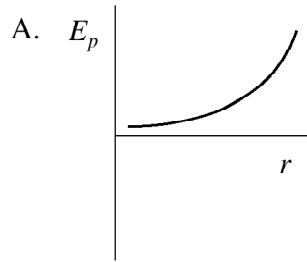

12.

How much work must be done to lift a  $4.00 \times 10^4$  kg object from Earth's surface to a height of  $3.00 \times 10^5$  m?

- A.  $1.12 \times 10^{11}$  J
- B.  $1.18 \times 10^{11}$  J
- C.  $2.39 \times 10^{12}$  J
- D.  $5.32 \times 10^{13}$  J

13. An 884 kg satellite in orbit around a planet has a gravitational potential energy of  $-5.44 \times 10^{10}$  J. The orbital radius of the satellite is  $8.52 \times 10^6$  m and its speed is  $7.84 \times 10^3$  m/s.

- a) What is the mass of the planet? **(3 marks)**
- b) What is the kinetic energy of the satellite? **(2 marks)**
- c) What is the total energy of the satellite? **(2 marks)**

0101

14.

Which vector diagram best represents the acceleration,  $\vec{a}$ , and force,  $\vec{F}$ , for an object travelling along a circular path?

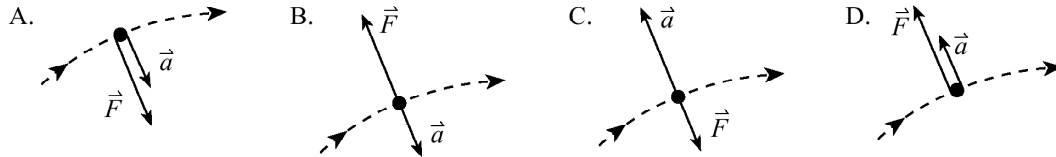
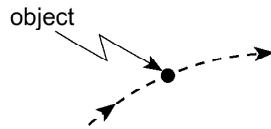

15.

An object travels along a circular path with a constant speed  $v$  when a force  $F$  acts on it. How large a force is required for this object to travel along the same path at twice the speed ( $2v$ )?

- A.  $\frac{1}{2}F$
- B.  $F$
- C.  $2F$
- D.  $4F$

16.

The diagram shows a 52 kg child riding on a Ferris wheel of radius 12 m and period 18 s. What force (normal force) does the seat exert on the child at the top and bottom of the ride?

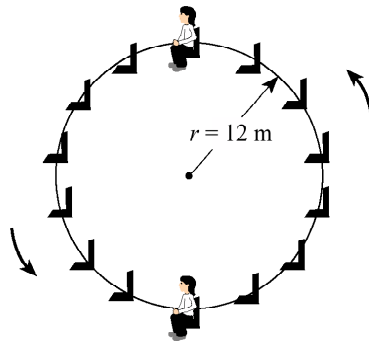

	TOP	BOTTOM
A.	76 N	76 N
B.	430 N	590 N
C.	510 N	510 N
D.	590 N	430 N



17.

The equation  $E_p = mgh$ , in which  $g$  is  $9.8 \text{ m/s}^2$ , can not be used for calculating the gravitational potential energy of an orbiting Earth satellite because

- A. the Earth is rotating.
- B. of the influence of other astronomical bodies.
- C. the Earth's gravity disappears above the atmosphere.
- D. the Earth's gravitational field strength varies with distance.

18.

The diagram shows an object of mass  $3.0 \text{ kg}$  travelling in a circular path of radius  $1.2 \text{ m}$  while suspended by a piece of string of length  $1.9 \text{ m}$ . What is the centripetal force on the mass?

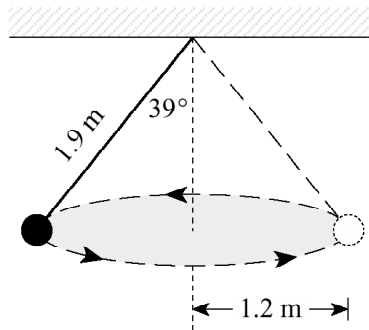

- A.  $19 \text{ N}$
- B.  $23 \text{ N}$
- C.  $24 \text{ N}$
- D.  $29 \text{ N}$

19.

- a) Mars has a mass of  $6.37 \times 10^{23}$  kg and a radius of  $3.43 \times 10^6$  m. What is the gravitational field strength on its surface? **(4 marks)**

- b) What thrust force must the rocket engine of a Martian lander exert if the 87.5 kg spacecraft is to accelerate upwards at  $1.20 \text{ m/s}^2$  as it leaves the surface of Mars? **(3 marks)**

0008

20.

A car travels at a uniform speed through a level circular curve in the road. Which of the following correctly describes the magnitude of the acceleration, velocity and force acting on the car?

	MAGNITUDE OF ACCELERATION	MAGNITUDE OF VELOCITY	MAGNITUDE OF FORCE
A.	constant	constant	constant
B.	constant	changing	changing
C.	constant	changing	constant
D.	changing	changing	changing

21.

An object is attached to a string that can withstand a maximum tension force of 6.3 N. The object travels in a circular path of radius 0.40 m with a period of 2.1 s.

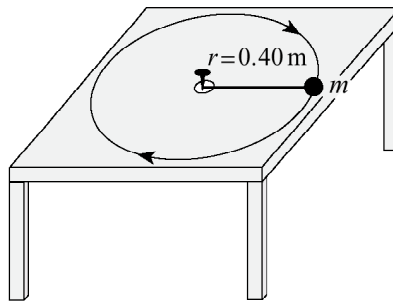

What is the maximum mass of the object?

- A. 0.57 kg
- B. 0.64 kg
- C. 1.8 kg
- D. 3.6 kg

22.

A 65 kg pilot in a stunt plane performs a vertical loop with a 700 m radius. The plane reaches a speed of 210 m/s at the bottom of the loop. What is the upward force on the pilot at the bottom of the loop?

- A. 640 N
- B. 3 500 N
- C. 4 100 N
- D. 4 700 N

23.

Which of the indicated areas of the graph represent the work needed to send an object from separation distance  $r$  to infinity?

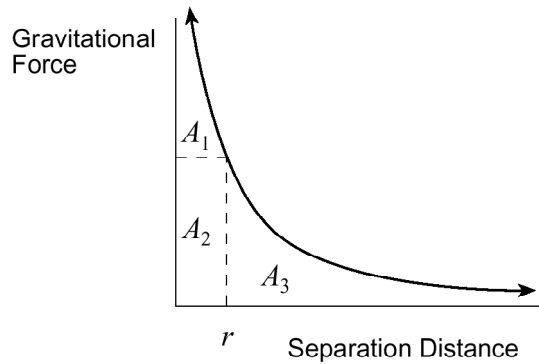

- A.  $A_1 + A_2$
- B.  $A_2$
- C.  $A_2 + A_3$
- D.  $A_3$

24.

A satellite experiences a gravitational force of 228 N at an altitude of  $4.0 \times 10^7$  m above Earth.

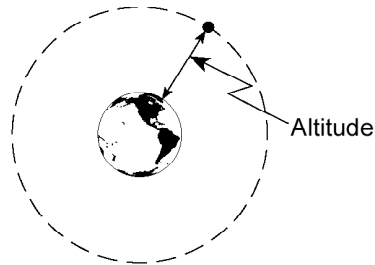

What is the mass of this satellite?

- A. 23 kg
- B. 650 kg
- C. 910 kg
- D. 1 200 kg

25.

A 1 570 kg satellite orbits a planet in a circle of radius  $5.94 \times 10^6$  m. Relative to zero at infinity the gravitational potential energy of this satellite is  $-9.32 \times 10^{11}$  J. What is the mass of the planet?

- A.  $5.29 \times 10^{25}$  kg
- B.  $8.31 \times 10^{28}$  kg
- C.  $3.14 \times 10^{31}$  kg
- D.  $4.93 \times 10^{34}$  kg

26.

A  $4.00 \times 10^3$  kg object is lifted from the earth's surface to an altitude of  $3.2 \times 10^5$  m.

How much work does this require?

**(7 marks)**

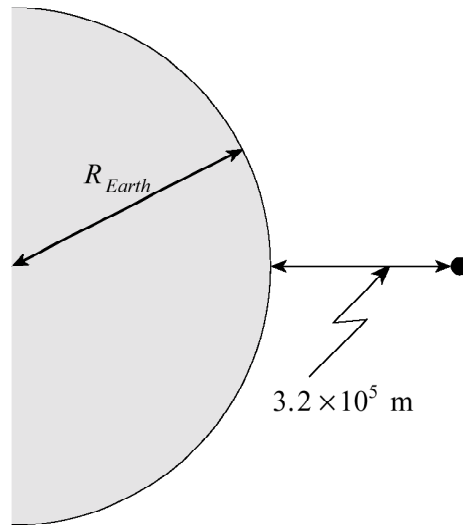

(Diagram not to scale.)

0006

27.

In a popular amusement park ride, a large cylinder is set in rotation. The floor then drops away leaving the riders suspended against the wall in a vertical position as shown.

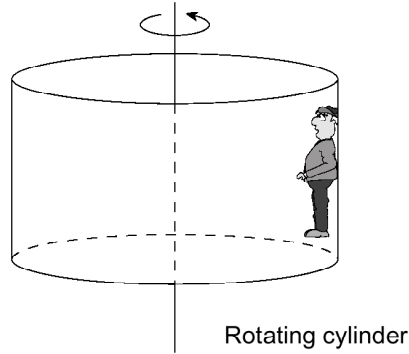

Which of the following is the correct free-body diagram for the person at the position shown?

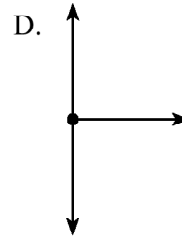
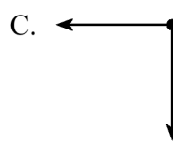
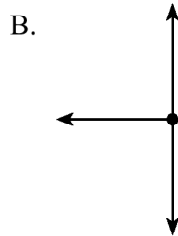
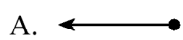

28.

A 0.500 kg ball is swung in a horizontal circle of radius 1.20 m with a period of 1.25 s. What is the centripetal force on the ball?

- A. 0.384 N
- B. 15.2 N
- C. 18.9 N
- D. 30.3 N

29.

A rock drops from a very high altitude towards the surface of the moon. Which of the following is correct about the changes that occur in the rock's mass and weight?

	MASS	WEIGHT
A.	decreases	decreases
B.	decreases	increases
C.	remains constant	decreases
D.	remains constant	increases

30.

Cavendish's historic experiment is set up as shown to determine the force between two identical sets of masses. What would be the net force of attraction between **one** set of masses?

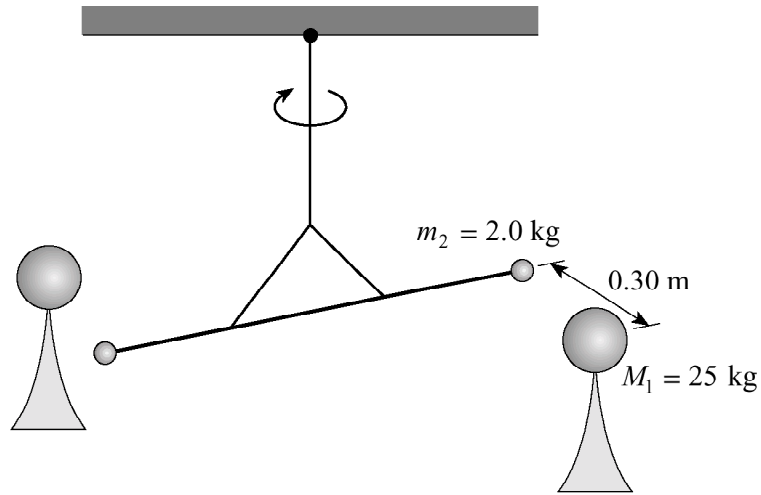

- A.  $1.1 \times 10^{-8}$  N
- B.  $1.9 \times 10^{-8}$  N
- C.  $2.2 \times 10^{-8}$  N
- D.  $3.7 \times 10^{-8}$  N

31.

A space shuttle is placed in a circular orbit at an altitude of  $3.00 \times 10^5$  m **above** Earth's surface.

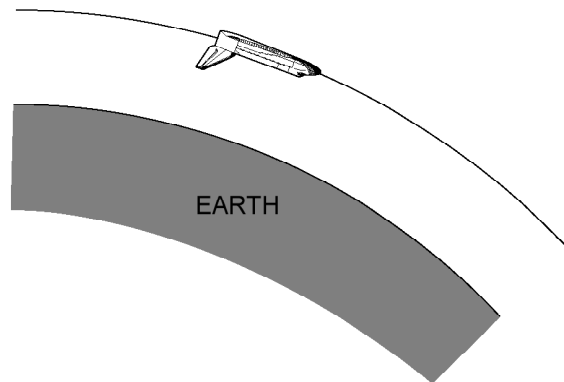

a) What is the shuttle's orbital speed?

(5 marks)

b) The space shuttle is then moved to a higher orbit in order to capture a satellite.

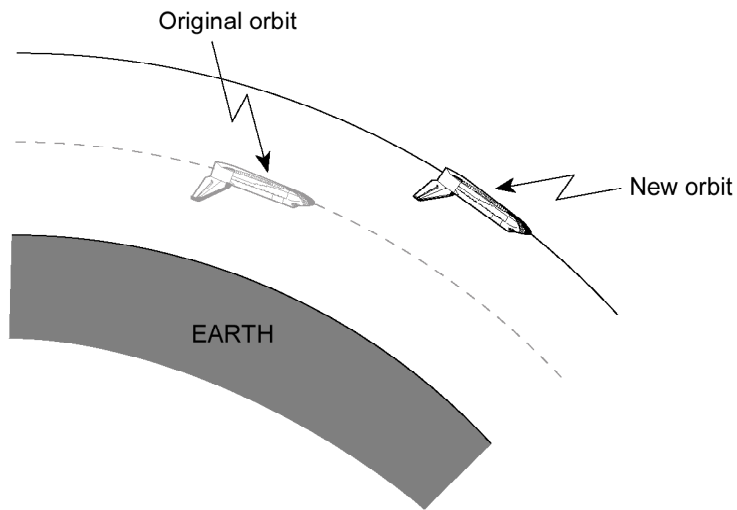

The shuttle's speed in this new higher orbit will have to be

- greater than in the lower orbit.
- less than in the lower orbit.
- the same as in the lower orbit.

(Check one response.)

**(1 mark)**

c) Using principles of physics, explain your answer to b).

**(3 marks)**

---

---

---

---

---

---



32.

A mass is suspended by a string attached to a spring scale that initially reads 14 N as shown in Diagram 1.

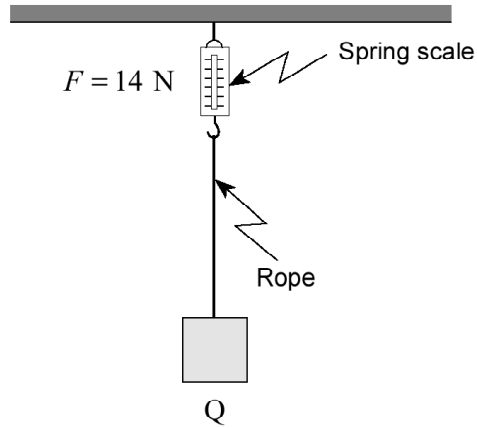

The mass is pulled to the side and then released as shown in Diagram 2.

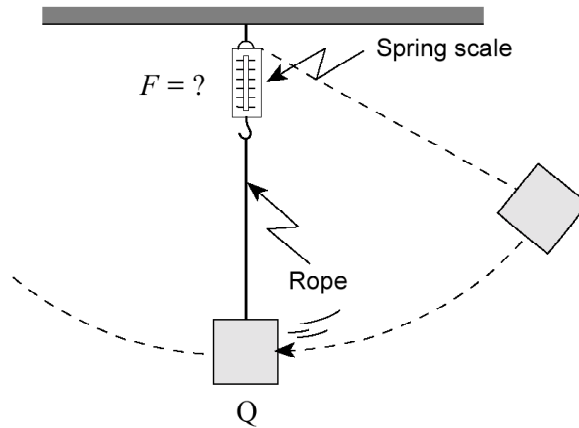

As the mass passes point Q, how will the reading on the spring scale compare to the previous value of 14 N? Using principles of physics, explain your answer. **(4 marks)**

---

---

---

---

---

---

---

---

0001  
33.

A ball attached to a string is swung in a horizontal circle.

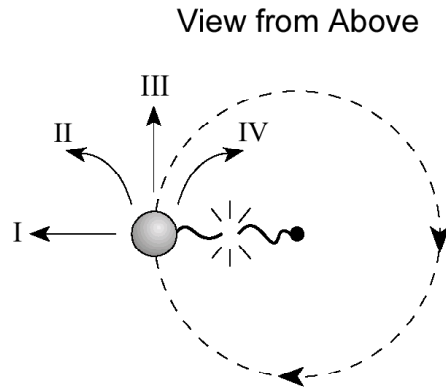

Which path will the ball follow at the instant the string breaks?

- A. I
- B. II
- C. III
- D. IV

34.

A test tube rotates in a centrifuge with a period of  $1.20 \times 10^{-3}$  s. The bottom of the test tube travels in a circular path of radius 0.150 m.

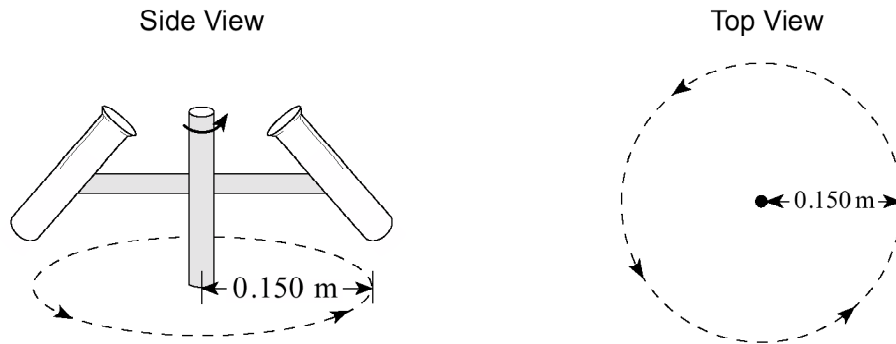

What is the centripetal force exerted on a  $2.00 \times 10^{-8}$  kg amoeba at the bottom of the tube?

- A.  $9.86 \times 10^{-5}$  N
- B.  $2.08 \times 10^{-3}$  N
- C.  $8.22 \times 10^{-2}$  N
- D.  $4.11 \times 10^6$  N

35.

A physics student swings a 5.0 kg pail of water in a vertical circle of radius 1.3 m.

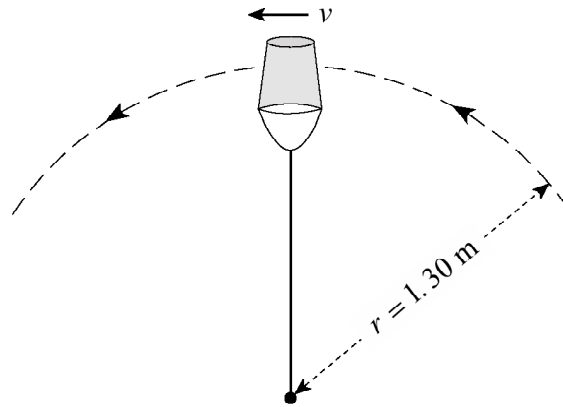

What is the minimum speed,  $v$ , at the top of the circle if the water is not to spill from the pail?

- A. 3.6 m/s
- B. 6.1 m/s
- C. 8.0 m/s
- D. 9.8 m/s

36.

*Sputnik I*, Earth's first artificial satellite, had an orbital period of 5 760 s. What was the average orbital radius of *Sputnik's* orbit?

- A.  $6.38 \times 10^6 \text{ m}$
- B.  $6.95 \times 10^6 \text{ m}$
- C.  $8.24 \times 10^6 \text{ m}$
- D.  $3.84 \times 10^8 \text{ m}$

37.

A 620 kg satellite orbits the earth where the acceleration due to gravity is  $0.233 \text{ m/s}^2$ . What is the kinetic energy of this orbiting satellite?

- A.  $-5.98 \times 10^9 \text{ J}$
- B.  $-2.99 \times 10^9 \text{ J}$
- C.  $2.99 \times 10^9 \text{ J}$
- D.  $5.98 \times 10^9 \text{ J}$

38.

A 5.0 kg rock dropped near the surface of Mars reaches a speed of 15 m/s in 4.0 s.

a) What is the acceleration due to gravity near the surface of Mars? **(2 marks)**

b) Mars has an average radius of  $3.38 \times 10^6$  m. What is the mass of Mars? **(5 marks)**

9908

39.

A small toy airplane suspended as shown below flies in a circular path.

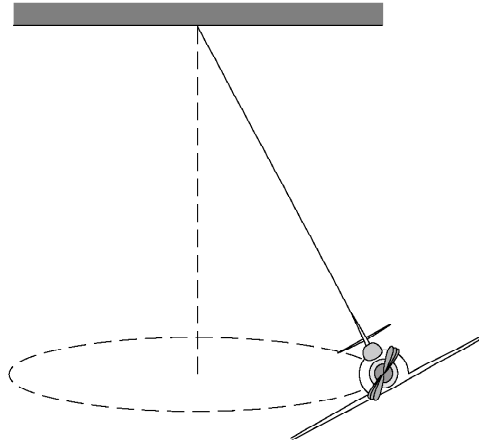

Which of the following free body diagrams best describes the forces acting on the airplane at the position shown?

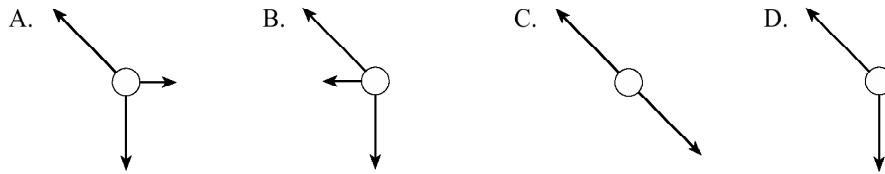

40.

An empty 12 kg seat on a swing-type ride at the fairgrounds has a kinetic energy of 480 J.

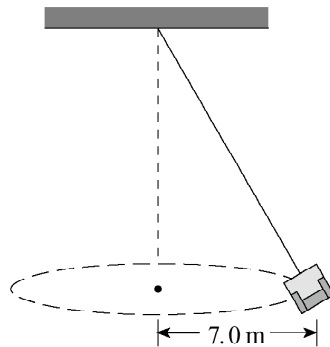

What is the centripetal force on the empty seat?

- A.  $1.2 \times 10^2$  N
- B.  $1.4 \times 10^2$  N
- C.  $8.2 \times 10^2$  N
- D.  $5.8 \times 10^3$  N

41.

A 75 kg person rides a Ferris wheel which is rotating uniformly. The centripetal force acting on the person is 45 N.

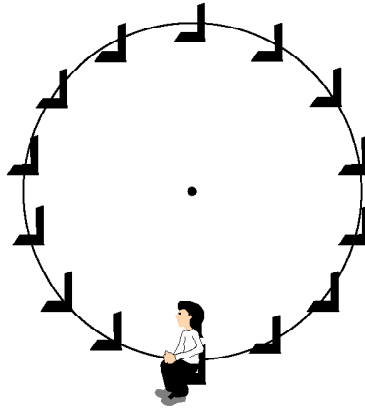

What force does the seat exert on the rider at the top and at the bottom of the ride?

	FORCE AT TOP	FORCE AT BOTTOM
A.	690 N	690 N
B.	690 N	780 N
C.	780 N	690 N
D.	780 N	780 N

42.

Which of the following illustrates the work required to move an object in a gravitational field?

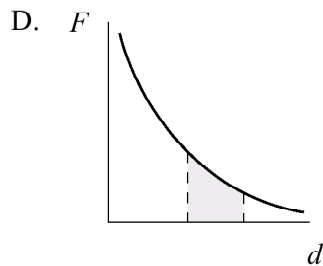
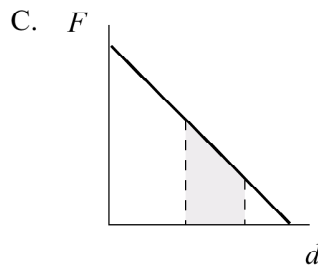
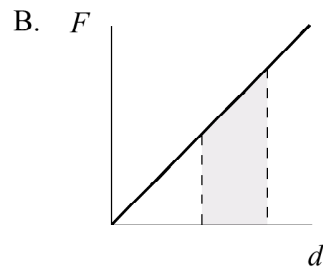
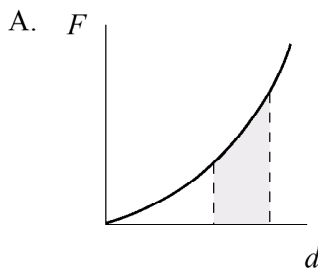

43.

A 1 500 kg satellite travels around the earth in a stable orbit with a radius of  $1.3 \times 10^7$  m.

a) What is the speed of the satellite in this orbit?

**(5 marks)**

b) The satellite is then moved to a new orbit with twice the radius of the first orbit. The speed in this orbit is

- the same as
- less than
- more than

the speed in the first orbit. (Check one response.)

**(1 mark)**

c) Using principles of physics, explain your answer to b).

**(3 marks)**

---

---

---

---

---

---



9906

44.

A satellite moves in a circular path at a constant speed. Which vector in the diagram below best represents the satellite's acceleration?

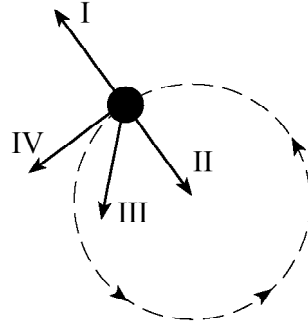

- A. I
- B. II
- C. III
- D. IV

45.

A 2.5 kg object moves at a constant speed of 8.0 m/s in a 5.0 m radius circle. What is the object's acceleration?

- A. 0 m/s<sup>2</sup>
- B. 1.6 m/s<sup>2</sup>
- C. 13 m/s<sup>2</sup>
- D. 32 m/s<sup>2</sup>

46.

What is the magnitude of Earth's centripetal acceleration as it orbits the Sun?

- A.  $1.9 \times 10^{-10} \text{ m/s}^2$
- B.  $4.2 \times 10^{-4} \text{ m/s}^2$
- C.  $5.9 \times 10^{-3} \text{ m/s}^2$
- D.  $9.8 \text{ m/s}^2$

47.

A student plots a graph of centripetal force  $F_c$  versus the square of velocity  $v^2$  for an object in uniform circular motion.

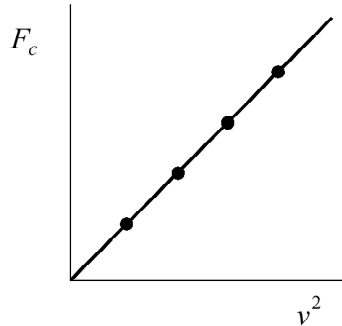

What is the slope of this graph?

- A.  $\frac{m}{r}$
- B.  $\frac{r}{m}$
- C.  $\frac{4\pi^2 r}{T^2}$
- D.  $\frac{T^2}{4\pi^2 r}$

48.

Which of the following is a correct expression for the total energy of the orbiting satellite shown below?

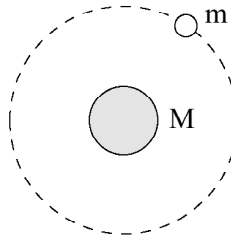

- A.  $E_T = -G \frac{Mm}{r}$
- B.  $E_T = G \frac{Mm}{r}$
- C.  $E_T = \frac{1}{2}mv^2 + mgr$
- D.  $E_T = \frac{1}{2}mv^2 + \left(-G \frac{Mm}{r}\right)$

49.

A 1 500 kg satellite travels in a stable circular orbit around the earth. The orbital radius is  $4.2 \times 10^7$  m. What is the satellite's kinetic energy? **(7 marks)**

**Scholarship Questions. Nasty, but cool!!!!**

9401

50.

An unpowered projectile is fired vertically upwards from the surface of the Moon. To what height above the surface will the projectile rise if it leaves the surface at 1 500 m/s? **(10 marks)**

9406

51.

A certain asteroid has a radius of  $7.0 \times 10^3$  m and a mass of  $5.0 \times 10^{15}$  kg. How fast would a cyclist have to travel on the surface of this asteroid in order for her apparent weight to be one fifth of her weight when stationary? **(10 marks)**

9501

52.

A certain planet has a radius of  $3.40 \times 10^6$  m and a mass of  $6.40 \times 10^{23}$  kg. An unpowered projectile is fired vertically upwards from the surface of this planet. To what height above the surface will the projectile rise if it leaves the surface at 1 600 m/s? **(12 marks)**

9506

53.

A student on a distant planet performs a “loop-the-loop” experiment. She releases a frictionless, 1.3 kg cart from a height of 4.50 m. It is observed that the track exerts a downward, normal reaction force of 21 N on the cart at the top of the circle. Calculate the gravitational field strength on the distant planet. **(12 marks)**

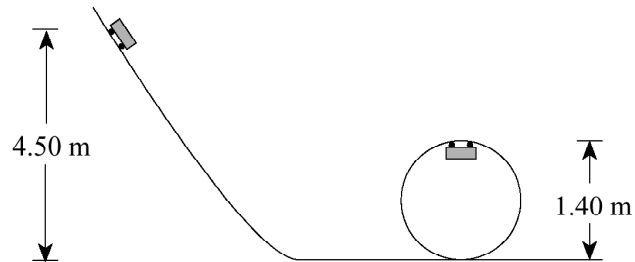

9508

54.

A racetrack surface has the shape of an inverted cone on which cars race in horizontal circles. For a steady speed of 29 m/s, to what distance  $d$  should a driver take her car, if she wishes to stay on a circular path without friction? **(12 marks)**

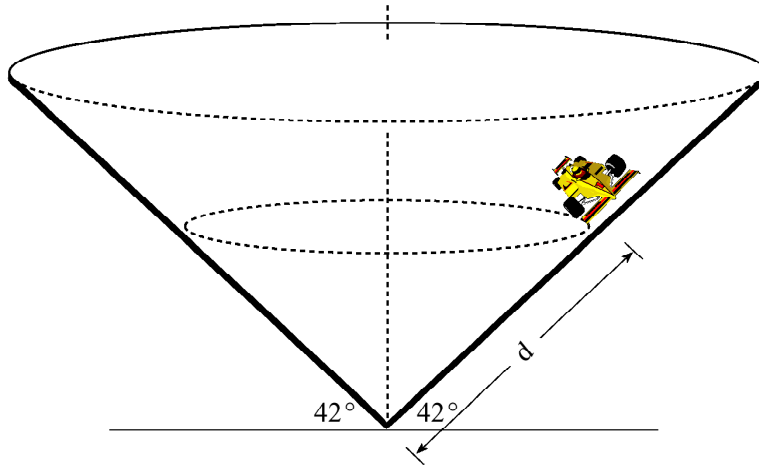



9601

55.

A 1 500 kg satellite is in orbit 250 km above Earth's surface. What minimum additional energy is needed to place this satellite in a new stable orbit 800 km above Earth's surface? **(12 marks)**

**Answers:**

1. b
2. d
3. b
4. a
5. b
6. a
7. 30 J
8. a
9. b
10. c
11. d
12. a
13. a)  $7.86 \times 10^{24}$  kg, b)  $2.72 \times 10^{10}$  J,  
c)  $-2.72 \times 10^{10}$  J
14. a
15. d
16. b
17. d
18. c
19. a) 3.61 N/kg, b) 421 N
20. a
21. c
22. d
23. d
24. d
25. a
26.  $W=1.2 \times 10^{10}$  J
27. b
28. b
29. d
30. d
31. a)  $7.73 \times 10^3$  m/s b) less than in  
the lower orbit c) see key
32. see key
33. c
34. c
35. a
36. b
37. c
38. a)  $3.8 \text{ m/s}^2$ , b)  $6.5 \times 10^{23}$  kg
39. d
40. b
41. b
42. d
43. a)  $5.5 \times 10^3$  m/s b) less than c)  
see key
44. b
45. c
46. c
47. a
48. d
49.  $7.1 \times 10^9$  J
50.  $1.2 \times 10^6$  m
51. 6.2 m/s
52.  $4.0 \times 10^5$  m
53.  $g=2.06$  N/kg
54. 130 m
55.  $3.41 \times 10^9$  J